

With Top Angles of 60° and 90° for Clamping the Hollow Workpieces.

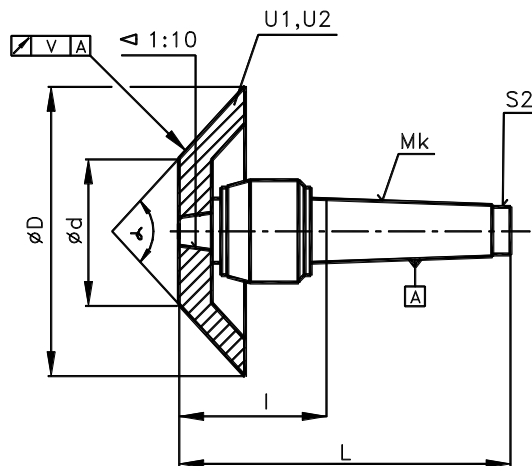

These live centres are intended for a quick and simple clamping of workpieces, when turning them on lathes, if these workpieces cannot be clamped by centres of current types, due to their hollows of big sizes. The live part of the centre is provided with a taper 1:10, which can carry, if need be, a tapered clamping insert with top angles of 60° (U1) or of 90° (U2). The insert is fixed to centre live part by a pressure generated by the tailstock sleeve. The disassembly of this insert is carried – out by knocking the centre shaft end (at best when holding it in hand). The live centres delivered are lubricated with lithium – type lubricating grease of LV 2-3 Grade. At extreme operation conditions we recommend an additional lubrication in time extents of 300 hours of operation with a quantity up to 1g being pressed into hole of bush head (blinded-up by screw S1) and up to 0.5 g being pressed into another hole situated at tapered shaft end (blinded-up by screw S2). Disassembly of live centres is not recommended.

In the range of standard execution, we deliver each live centre with a set of exchangeable clamping inserts, which correspond to size of MORSE-taper.

In the range of special execution, we deliver the live centres with clamping inserts according to your wishes and with max.  $\varnothing$  D according to the following table.

As a special execution, we also deliver the undismountable live centres – the clamping inserts cannot be disassembled. Separate clamping inserts are even delivered as spare parts (for standard, dismountable execution only).

Mk	$\alpha$	$\varnothing$ d	$\varnothing$ D	L	I	U	Q	G	Gv	V
3	60	35	80	162	81	5 000	400	2.1	0.63	0.025
	90	32							0.61	
4	60	44	115	194	92	4 000	1 300	4.4	1.56	
	90	47							1.40	
5	60	46	135	240	110	3 500	2 000	8.0	2.76	
	90	45							2.13	
6	60	64	170	308	126	2 500	4 000	23.5	5.15	
	90	70							3.85	
	90	96							230	

Dimensions in mm.

Legend:

Mk ... MORSE taper

U ... max. speed [r.p.m.]

Q ... max. weight of workpiece [kg] at 50 r.p.m. and life Lh = 500 operationg hours

G ... weight of the product [kg]

V ... max. roundness deviation